

Little Folks

- FURNITURE -

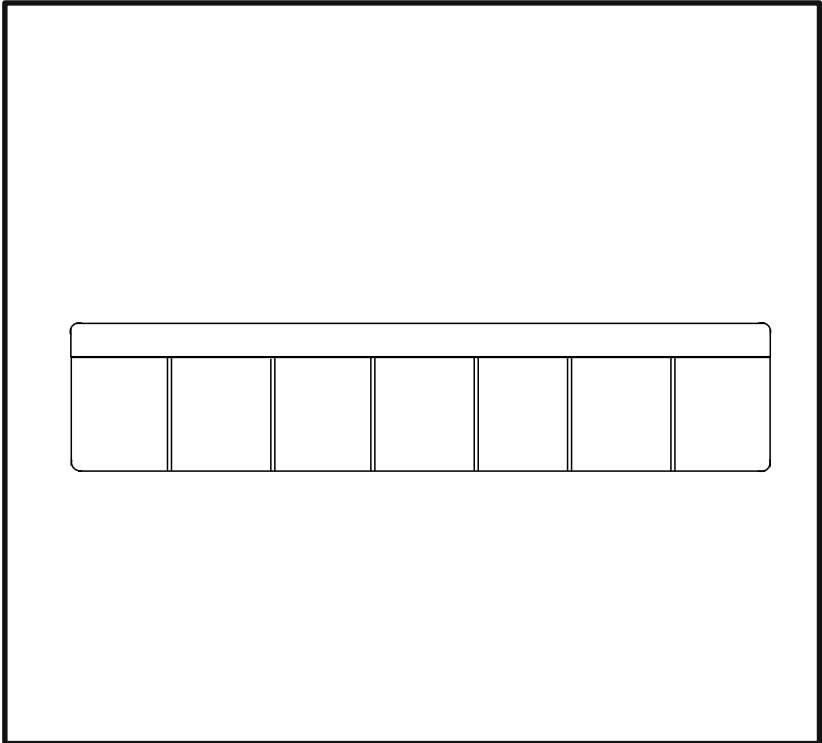

Fargo shelf

Code: SHF001

PLEASE READ CAREFULLY & KEEP FOR FUTURE REFERENCE

Thank you for buying a **Little Folks** piece of furniture

Treated properly it should be a faithful servant for years - and we hope you get the same amount of pleasure from it. Before you do

- please take a few minutes to read these instructions
- we suggest you carefully unpack everything, lay it out on a clean, flat floor and identify everything on the parts list in these instructions. Do not throw away any packaging until you are sure you have all the parts.

If you have any problems assembling the product please call our customer services on 01985 300588 and we will try and help. If for any reason you wish to return the product, you must disassemble the product and pack in the original packaging.

Taking care of your product

Your furniture should require no more than a regular dust off with a soft cloth. If the furniture is not painted then a superior wood polish can be used - but never use polishes containing silicone.

If necessary it can be cleaned with a damp cloth with a mild detergent solution - and then dried with a lint-free cloth. Never clean with abrasives or chemical cleaners.

Direct sunlight or heat from a radiator can stain, discolour warp or crack furniture.

We know furniture can be heavy but try not to drag furniture across the floor as this can damage it.

PRODUCT SAFETY

Periodically check all fittings to ensure that none have come loose.

Keep away from direct sources of heat, such as electric, gas or wood fires.

Do not allow children to climb on the furniture. Larger items of furniture should be properly (and professionally) secured to the wall to prevent them toppling over.

Using this furniture other than for its intended purpose could cause damage to the structure or serious injury to your child.

The shelf should be securely secured to the bed and not used between other structures and furniture.

The furniture should not be used if any structural part is broken or missing.

Children can become trapped between the bed and wall. To avoid risk of serious injury the distance between the top safety barrier and the wall shall not exceed 75mm nor shall be more than 230mm.

CARE should be taken to avoid falling items, banging of heads and storing liquids.

If electrical items are to be used on the shelf, please adhere to the safety guidelines for that electrical item.

We recommend a maximum weight limit for the shelf at 2kg **DO NOT OVERLOAD**

The shelf has been designed for light storage use only.

If you have any problems please do contact us for help on e mail customerservices@littlefolksfurniture.co.uk or phone our **CUSTOMER SERVICES 01985 300588**

Parts list

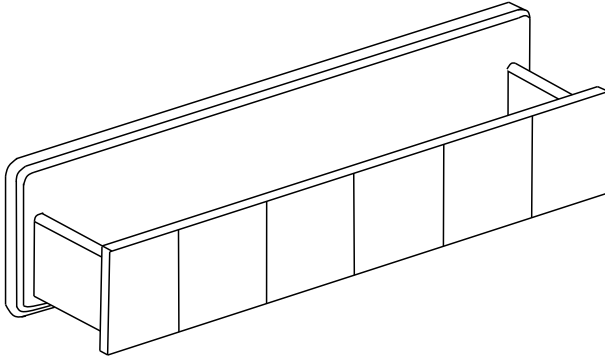

Fittings

4 x Bolts



2 x Screws (small)



4 x felt pads



2 x hooks

Tools Req

Screwdriver

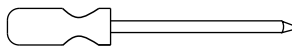

Fit the hooks

2 x hooks and 4 x bolts

Insert the hooks into the recessed slots seen on the back of the shelf. Now align the holes and connect the hooks using the 4 x bolts.

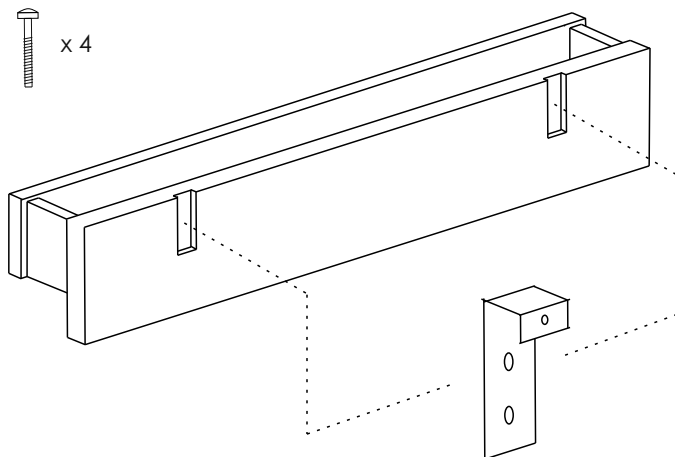

Apply the felt pads

4 x felt pads

Attach 2 x felt pads to the inside of the hook, removing the protective film to expose the adhesive beneath. Now fit 2 x felt pads to the inside of the shelf just below the hooks. See image

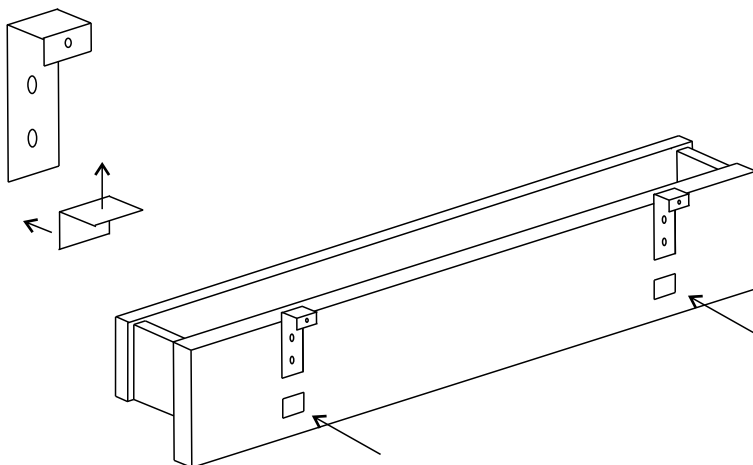

Connect the shelf

2 x small screws

hook the shelf over the mattress rail (hi-sleeper) or onto the guard rail (bunk bed)
Once firmly in position, with the hooks fully over the supporting rails, secure both hooks with the small screws provided.

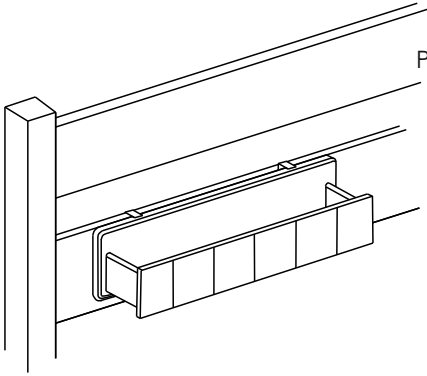

Position of the shelf on the Hi-sleeper bed

Position of shelf on the bunk bed

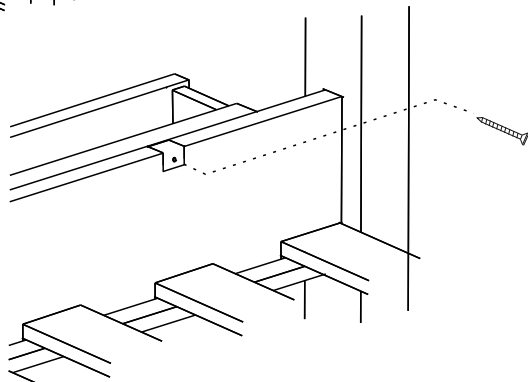
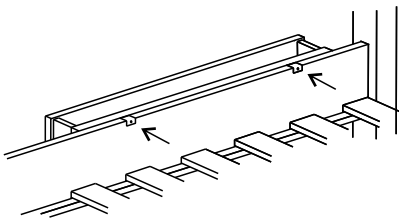
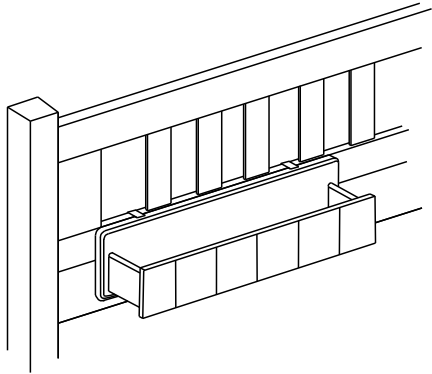

Note

The shelf is designed to be connected to the bed using the two metal hooks and secured using the two smaller screws.

Care should be taken when using the shelf as not to dislodge, overload or use the shelf outside of its intended purpose.

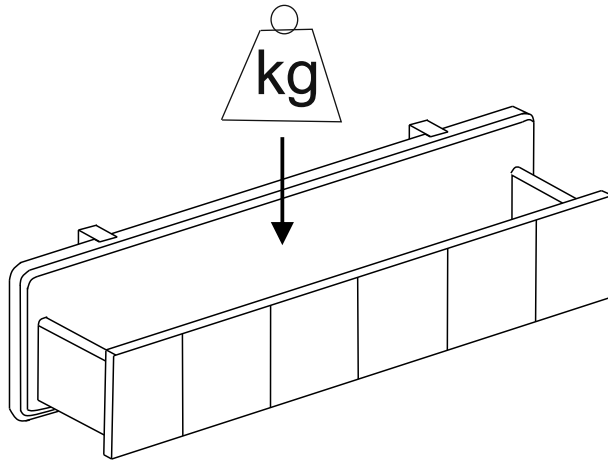

Orientation and use.

The shelf should only be used as illustrated in these instructions.
DO NOT OVERLOAD.