

Little Folks

- FURNITURE -



Classic Single Bed

Code: SBD011

PLEASE READ CAREFULLY & KEEP FOR FUTURE REFERENCE

AXE100523

Thank you for buying a **Little Folks** piece of furniture

Treated properly it should be a faithful servant for years - and we hope you get the same amount of pleasure from it. Before you do

- please take a few minutes to read these instructions
- we suggest you carefully unpack everything, lay it out on a clean, flat floor and identify everything on the parts list in these instructions. Do not throw away any packaging until you are sure you have all the parts.

If you have any problems assembling the product please call our customer services on 01985 300588 and we will try and help. If for any reason you wish to return the product, you must disassemble the product and pack in the original packaging.

Taking care of your product

Your furniture should require no more than a regular dust off with a soft cloth. If the furniture is not painted then a superior wood polish can be used - but never use polishes containing silicone.

If necessary it can be cleaned with a damp cloth with a mild detergent solution - and then dried with a lint-free cloth. Never clean with abrasives or chemical cleaners.

Direct sunlight or heat from a radiator can stain, discolour warp or crack furniture.

We know furniture can be heavy but try not to drag furniture across the floor as this can damage it.

PRODUCT SAFETY

The recommended size of the mattress is 190cm x 91cm (6`3" x 3`0)

Periodically check all fittings to ensure that none have come loose.

Keep away from direct sources of heat, such as electric, gas or coal fires.

Do not allow children to Climb on the furniture.

Using this furniture other than for its intended purpose could cause damage to the structure or serious injury to your child.

If you can manage it, please try to persuade your children not to bounce on the bed.

Always follow the manufacture`s instructions.

Warning: The child`s bed should not be placed too close to other furniture or windows, blind cords, curtain pulls or other strings or cords, and should be placed either tight to any wall or have a gap of 300mm between the wall and the side of the bed.

WARNING: Do not use the bed if any structural part is broken or missing; Please ensure that good ventilation is maintained within the room in order to keep humidity low and to prevent mould in and around the bed.

If you have any problems please do contact us for help on email customerservices@littlefolksfurniture.co.uk or phone our CUSTOMER SERVICES 01985 300588

Parts

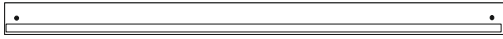

2 x mattress rails

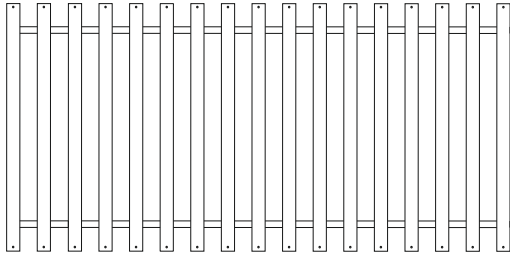

1 x mattress base

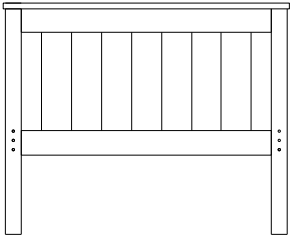

1 x large end

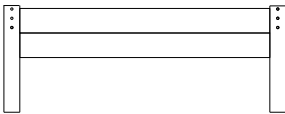

1 x low footboard

Fittings

4 x 9cm Bolts



4 x Barrel Nuts



8 x small Dowels



34 x Screws 3.5cm



1 x Allen Key

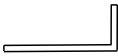

Tools Req

Screwdriver

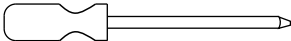

small hammer



Fitting the rails

8 x small wooden dowels

Insert 2 wooden dowels into each end of each rail

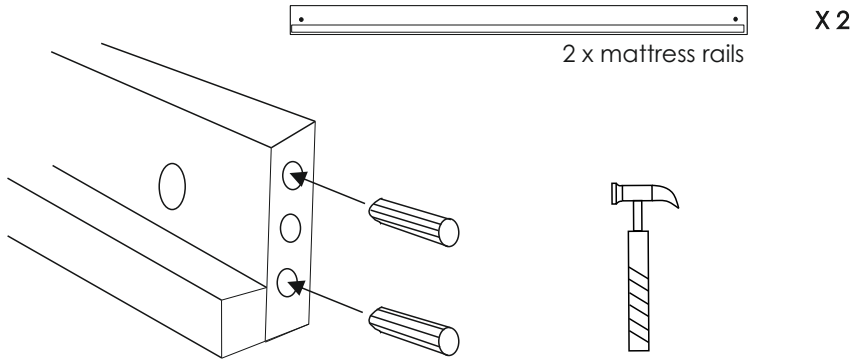

Building the bed frame (Two people)

4 x 9cm bolts and 4 x barrel nuts

Build the bed with the parts positioned as shown (mattress support piece on the lower edge of the mattress rail). Locate the wooden dowels (fitted in the mattress rails) into the holes in the two bed frames. Insert a barrel nut into the hole at each end of the mattress rails, aligning it as to connect to the long bolt fitted from the outside of the bed frames, rotate the bolts to tighten the bed frames.

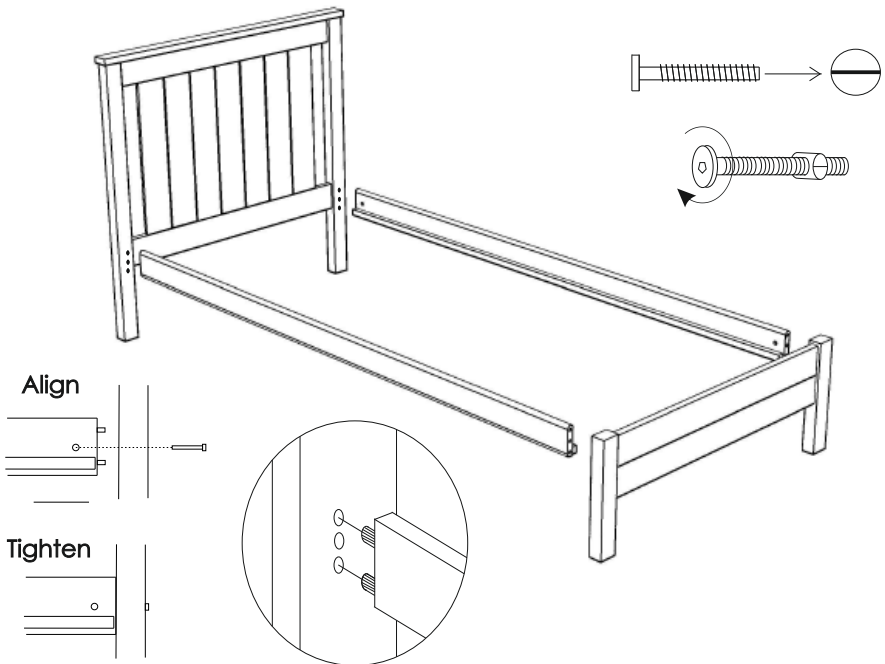

Fit the lower bed mattress base

34 x screws

Carefully roll out the mattress base onto the mattress support pieces fitted on the inside of the mattress rails, webbing on the underside. Starting at one end of the bed, push the end lath tight up against the bed legs and screw in place using the two end holes in the lath. Now push the other end lath tight up against the bed legs at the opposite end of the bed, screwing down to secure. Once both ends of the base are fitted, position yourself at the centre of the bed, now fix each end of the central lath making sure that the lath is tight against the both mattress rails(some gentle inward pressure will help). Once these three laths are fixed, secure the remaining base laths, screwing down each lath in turn. Repeat the process on the upper bed end

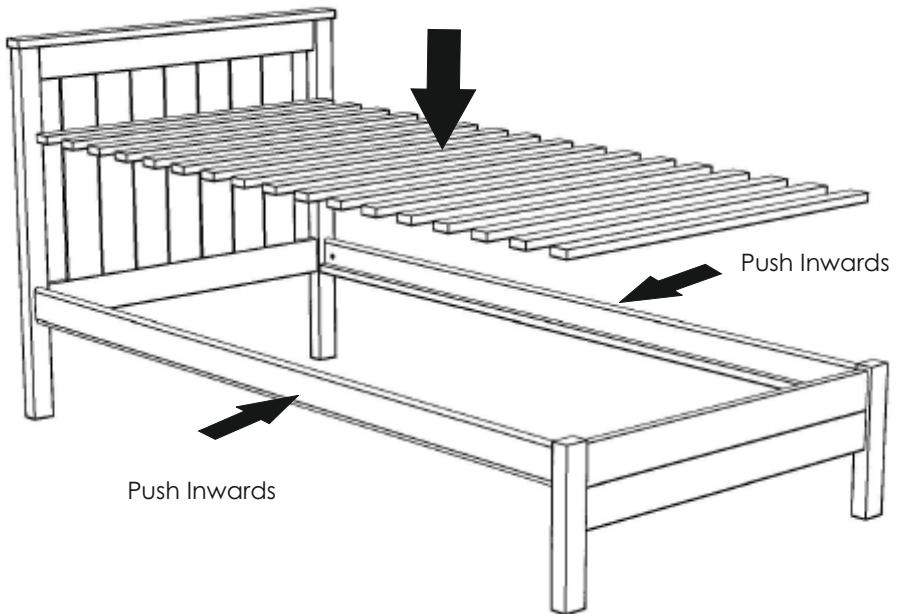

PRODUCT SAFETY

Additional information

Periodically check that all assembly fixings are tightened properly, care should be taken to ensure that no fittings are loose.

Always follow the manufacture`s instructions.

Please ensure that good ventilation is maintained within the room in order to keep humidity low and to prevent mould in and around the bed;

WARNING Do not place this child`s bed near heat sources, windows and other furniture.

WARNING Do not use this child`s bed if any part is broken, torn or missing.

WARNING Hole covers Not suitable for children under 36 months due to choking hazard.

The bed can be dismantled for storage or transportation.

Children are likely to play, bounce, jump and climb on beds, therefore the child`s bed should not be placed too close to other furniture or windows, blind cords, curtain pulls or other strings or cords and should be placed either tight to any wall or have a gap of 300mm between the wall and the side of the bed.

Additional or replacement parts should be obtained from Little Folks Furniture.

Moving the bed

Do Not drag the bed.

Lift the bed into place by supporting both the end bed frames and mattress rails, keeping the bed assembly all together and in unison. Removing the mattress will reduce the weight of the product and help assist with repositioning the product.



Please take a few minutes to look over the bed to ensure that the fittings are securely fastened and the product is stable.