

Little Folks

- FURNITURE -

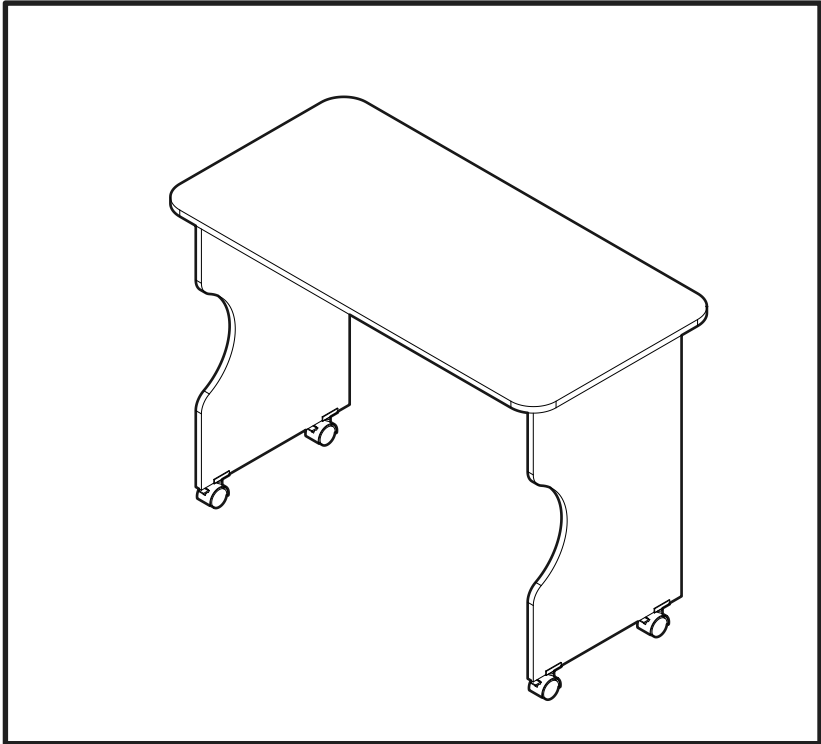

Roll Out Desk

Code: DSK006

PLEASE READ CAREFULLY & KEEP FOR FUTURE REFERENCE

Thank you for buying a **Little Folks** piece of furniture

Treated properly it should be a faithful servant for years - and we hope you get the same amount of pleasure from it. Before you do

- please take a few minutes to read these instructions
- we suggest you carefully unpack everything, lay it out on a clean, flat floor and identify everything on the parts list in these instructions. Do not throw away any packaging until you are sure you have all the parts.

If you have any problems assembling the product please call our customer services on 01985 300588 and we will try and help. If for any reason you wish to return the product, you must disassemble the product and pack in the original packaging.

Taking care of your product

Your furniture should require no more than a regular dust off with a soft cloth. If the furniture is not painted then a superior wood polish can be used - but never use polishes containing silicone.

If necessary it can be cleaned with a damp cloth with a mild detergent solution - and then dried with a lint-free cloth. Never clean with abrasives or chemical cleaners.

Direct sunlight or heat from a radiator can stain, discolour, warp or crack furniture.

We know furniture can be heavy but try not to drag furniture across the floor as this can damage it.

PRODUCT SAFETY

Periodically check all fittings to ensure that none have come loose.

Keep away from direct sources of heat, such as electric, gas or wood fires.

Do not allow children to climb on the furniture. Larger items of furniture should be properly (and professionally) secured to the wall to prevent them toppling over. Little Folks Furniture do not supply wall fixings due to the wide ranging differences of wall construction.

Warning: This work should only be carried out by a competent person or a professional.

Using furniture other than for its intended purpose could cause damage to the structure or serious injury to your child.

The furniture should not be used if any structural part is broken or missing.

Do not place heavy or unsuitable sized items on the furniture due to risk of falling and injury.

Lock castor wheels when positioned and un-lock the castor wheels to move.

Do not roll across un-even flooring due to risk of damage and tipping.

Remove all items from the upper surface when re-positioning as to eliminate the possibility of falling hazards.

If used under an upper bed, align the furniture under the bed as not to generate projections which might be used as a foot-hold or ledge.

If you have any problems please do contact us for help on email customerservices@littlefolksfurniture.co.uk or phone our **CUSTOMER SERVICES 01985 300588**

Components - Panels

Please check you have all the panels listed below



Important - Thick lines  indicate finished edges



2143 Top (100.0x49.6cm)

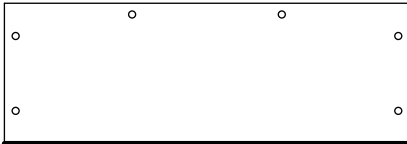

2146 Back Rail (86.6x30.0cm)

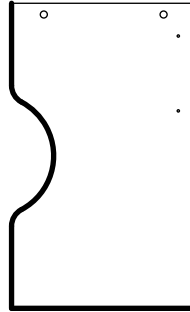

2144 Lh End Panel
(65.2 x 39.4cm)

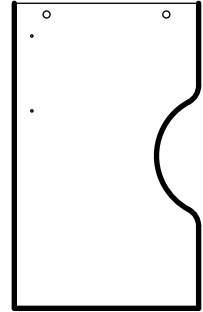







2145 Rh End Panel
(65.2 x 39.4cm)

Components - Fittings

Please check you have all the fittings listed below

Note: The quantities below are the correct amount to complete the assembly, In some cases more fittings may be supplied than are required.

<p>A  Large cam x 10 Code 760001103</p>	<p>B  Metal dowel x 10 Code 760003004</p>	<p>C  12mm screw x 2 Code 690001099</p>
<p>D  L bracket x 1 Code 760001901</p>	<p>E  22mm screw x 8- Code 690001018</p>	<p>F  Caster x 4 Code 722009121</p>

Tools required

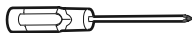

Large Cross
Headed
Screwdriver

Ruler - Use this ruler to help correctly identify the screws

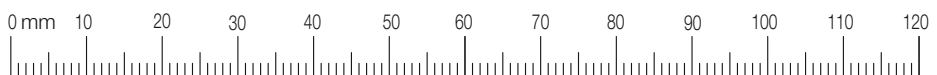

Assembly Instructions

Step 1

Fitting dowels to top panel.

Insert 6 metal dowels **B** into the top panel **2143**

Note: Tighten metal dowels up fully against the panel.

Do not over-tighten.

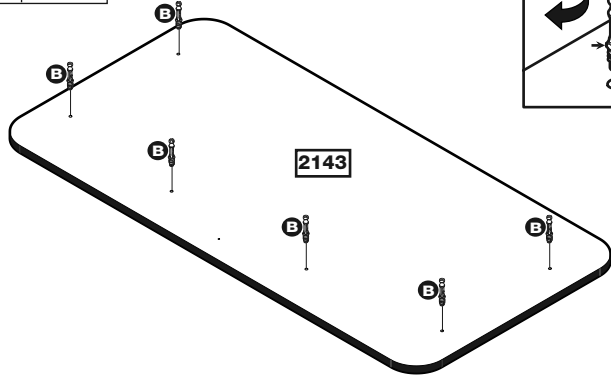

Step 2

Fitting cams and dowels to the end panels.

Insert 2 cams **A** into the lh end panel **2144**

Insert 2 metal dowels **B** into the lh end panel **2144**

Insert 2 cams **A** into the rh end panel **2145**

Insert 2 metal dowels **B** into the rh end panel **2145**

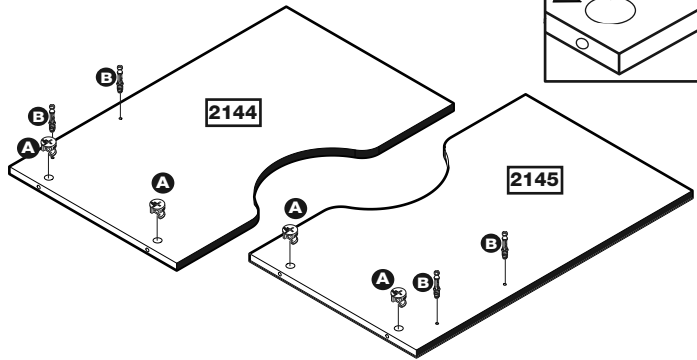

Step 3

Fitting cams and back rail.

Insert 6 cams **A** into the back rail **2146**

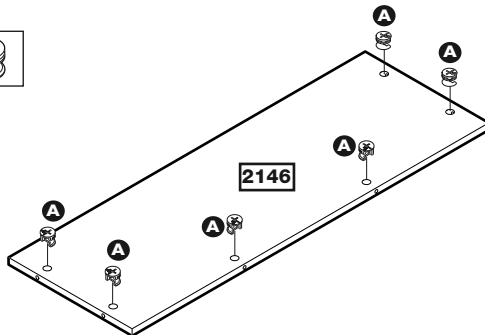

Assembly Instructions

Step 4

Connect the end panels to the back rail.

Connect the cams in the back rail **2146** to the metal dowels in the end panels **2144** and **2145**.

Turn the cam 180 degrees to lock.

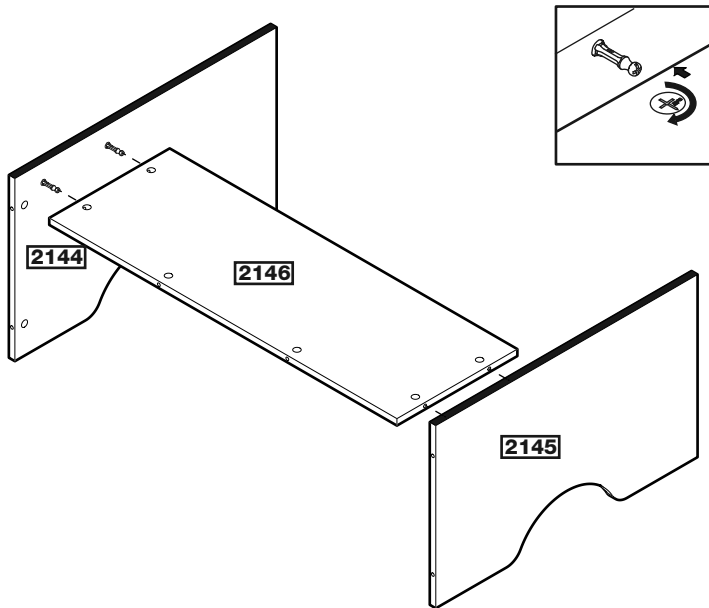

Step 5

Connect the ends and divider panels to the top panel.

Connect the cams in the end panels **2144** and **2145** and back rail **2146** to the metal dowels in the top panel **2143**.

Turn the cam 180 degrees to lock.

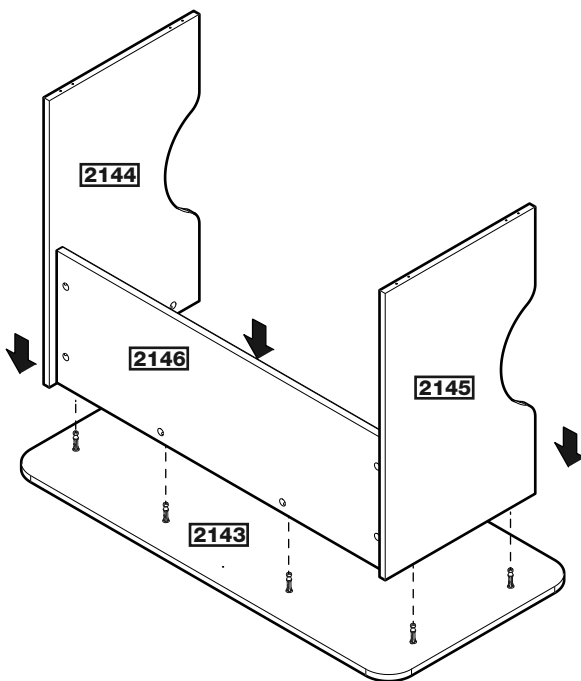

Assembly Instructions

Step 6

Fasten the castors to the end panels.

Secure the castors **F** in place by using screws **E** and screwing into the pre-drilled holes in the end panels **2144** and **2145**.

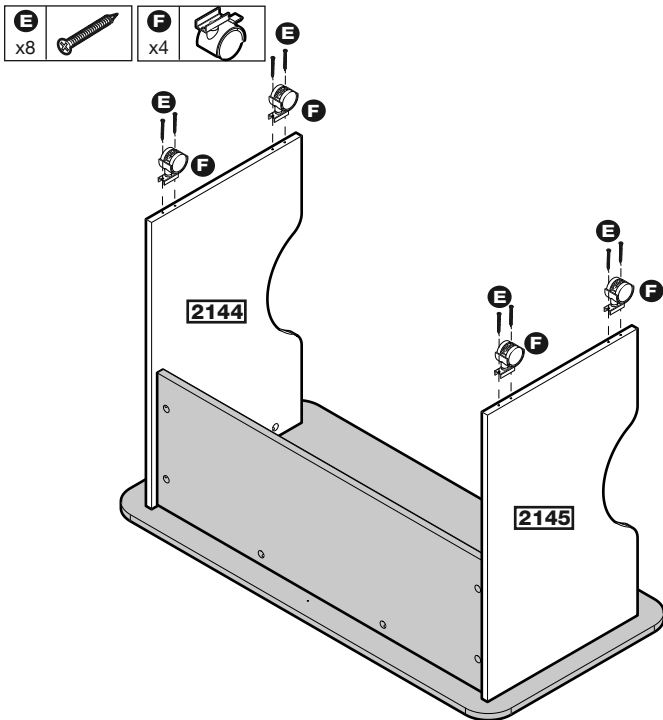

Step 7

Stand the unit upright and check movement.

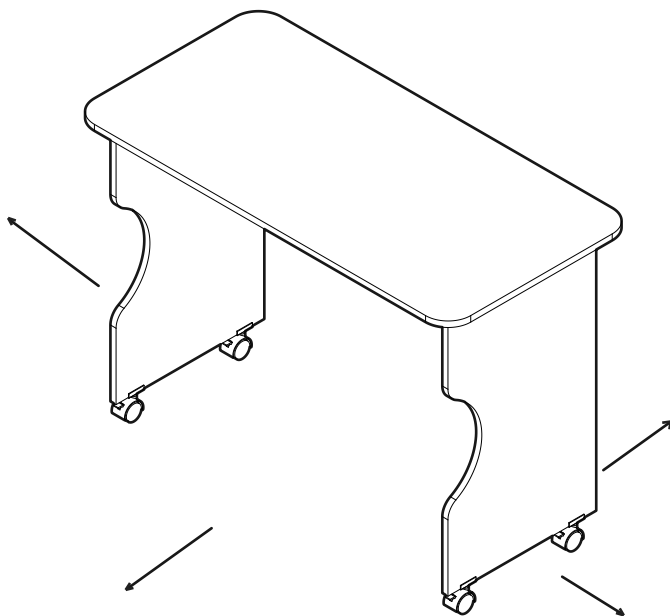

Assembly Instructions

Step 8

Placing the roll out desk - IMPORTANT

See below guidelines.

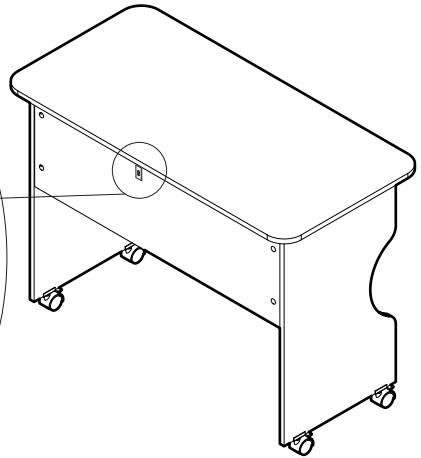
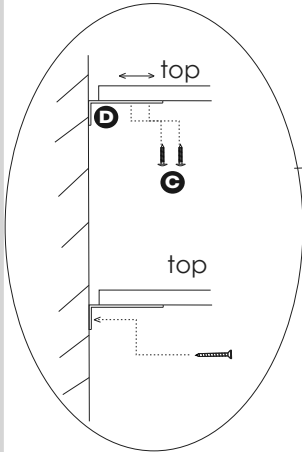

Free standing use - outside the confines of a furniture structure (bed, desk etc) Orientate the desk with the back facing the wall. Position the wall bracket to take up the difference between unit and wall surface (bridging over a skirting board), tighten the unit screw to secure. Now mark the wall for the position of the wall fixing. Gently wheel the desk away from the wall to make a fixing that is suitable for the wall type you have. Re-position the desk and physically connect the unit to the wall.

Step 9

Lock castors to prevent movement

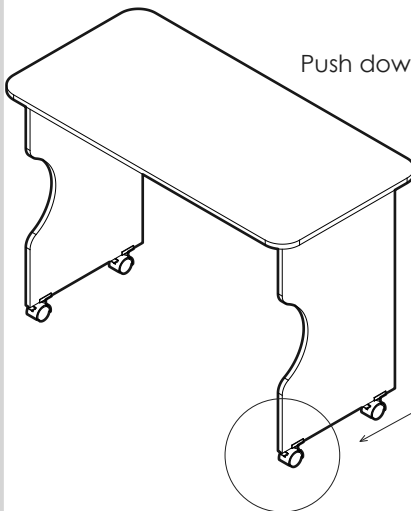

Push down lever to lock castor

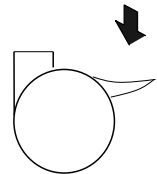

Assembly Instructions

Step 10

Final check

If used away from an furniture structure (e.g bed or desk), please ensure that the wall bracket is connected to both the desk and a suitable wall structure.

If used under a bed please check that the unit is neatly aligned and does not create ledges of foot holds for the upper bed.

Check that the castor wheels are “locked” in place and positioned on a level floor.

Do not overload, store heavy items or place unsuitable sized items on the desk due to the risk of injury from falling hazards.

Do not attach items such as ropes, strings, cords, harnesses or belts etc to avoid the risk of strangulation.

WARNING: Children can become trapped between bed furniture and the wall. To avoid the risk of serious injury the distance between furniture and the wall shall not exceed 75mm nor shall be more than 230mm.

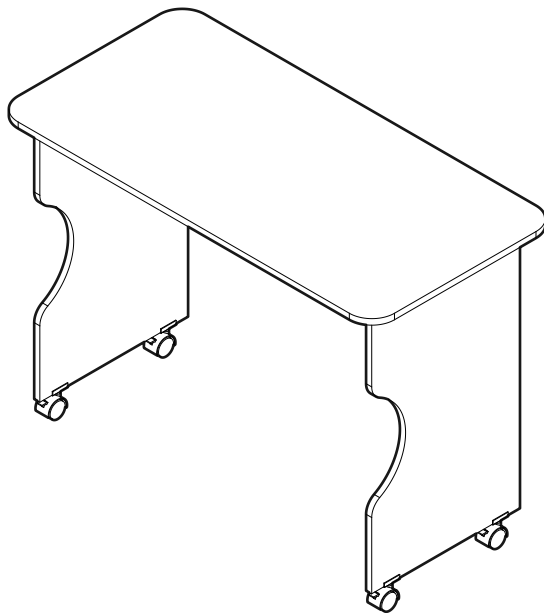

Congratulations! Your unit is complete.