

Little Folks

- FURNITURE -



Edit Bunk Bed

Code: BBD008

PLEASE READ CAREFULLY & KEEP FOR FUTURE REFERENCE

Thank you for buying a **Little Folks** piece of furniture

Treated properly it should be a faithful servant for years - and we hope you get the same amount of pleasure from it. Before you do

- please take a few minutes to read these instructions
- we suggest you carefully unpack everything, lay it out on a clean, flat floor and identify everything on the parts list in these instructions. Do not throw away any packaging until you are sure you have all the parts.

If you have any problems assembling the product please call our customer services on 01985 300588 and we will try and help. If for any reason you wish to return the product, you must disassemble the product and pack in the original packaging.

Taking care of your product

Your furniture should require no more than a regular dust off with a soft cloth. If the furniture is not painted then a superior wood polish can be used - but never use polishes containing silicone.

If necessary it can be cleaned with a damp cloth with a mild detergent solution - and then dried with a lint-free cloth. Never clean with abrasives or chemical cleaners.

Direct sunlight or heat from a radiator can stain, discolour warp or crack furniture.

We know furniture can be heavy but try not to drag furniture across the floor as this can damage it.

PRODUCT SAFETY

This product is designed to conform to BSEN747:1 2012+A1:2015

The MAXIMUM thickness of the UPPER BUNK mattress is 23cm.

The recommended size of the mattress is 190cm x 91cm (6'3" x 3'0")

Periodically check that all assembly fixings are tightened properly, care should be taken to ensure that no fittings are loose.

Always follow the manufacture's instructions.

Please ensure that good ventilation is maintained within the room in order to keep humidity low and to prevent mould in and around the bed;

WARNING "High beds and the upper bed of bunk beds are not suitable for children under six years due to the risk injury from falls".

WARNING "Bunk beds and high beds can present a serious risk of injury from strangulation if not used correctly. Never attach or hang items to any part of the bunk bed that are not designed to be used with the bed, for example, but not limited to ropes, strings, cords, hooks, belts and bags"

WARNING "Children can become trapped between the bed and the wall, a roof pitch, the ceiling, adjoining pieces of furniture (e.g. cupboards) and the like. To avoid risk of serious injury the distance between the top safety barrier and the adjoining structure shall not exceed 75mm or shall be more than 230mm.

WARNING Do not use the bunk bed if any structural part is broken or missing;

WARNING Hole covers Not suitable for children under 36 months due to choking hazard.

If you have any problems please do contact us for help on e mail customerservices@littlefolksfurniture.co.uk or phone our CUSTOMER SERVICES 01985 300588

Parts

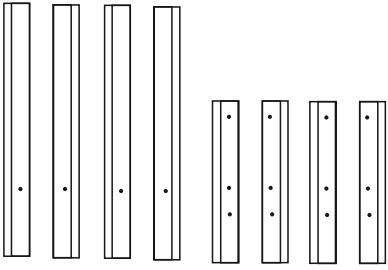

2 x upper legs R
2 x upper legs L
2 x lower legs R
2 x lower legs L



2 x lower rails - Left & Right
2 x lower rails - Left & Right

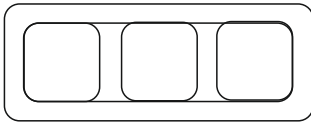

ladder frame

3 x ladder treads 

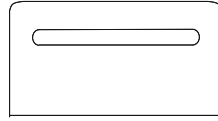

2 x upper ends

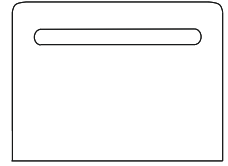

2 x lower ends

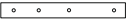
4 x supports 

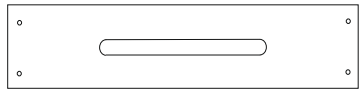

front safety panel



rear safety panel

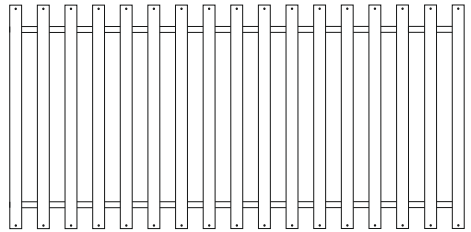

2 x mattress base

Fittings

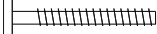
14 x Large Bolts 9cm 

6 x Bolts 4cm 

20 x Bolts 3.5cm 

4 x Large Dowels 

32 x Small Dowels 

14 x Barrel Nuts 

76 x Screws 3cm 

For assembly of the Bed ends.

24 x Cam Pins 

24 x Cam Sleeves 

24 x Cam Grub Screws 

Tools Req

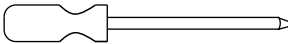
Screwdriver 

1 x Allen Key provided 

small hammer



Fit the bed panels

You need: 16 x wooden dowels & 16 cam sleeves

Lay each bed panel onto the floor (use packaging material to protect the parts) and gently insert (tap)the wooden dowels into the blind holes positioned on the bed panel edges ,as shown. Now gently insert the cam sleeves into the large holes on the flat face of each bed panel, orientating the internal holes.

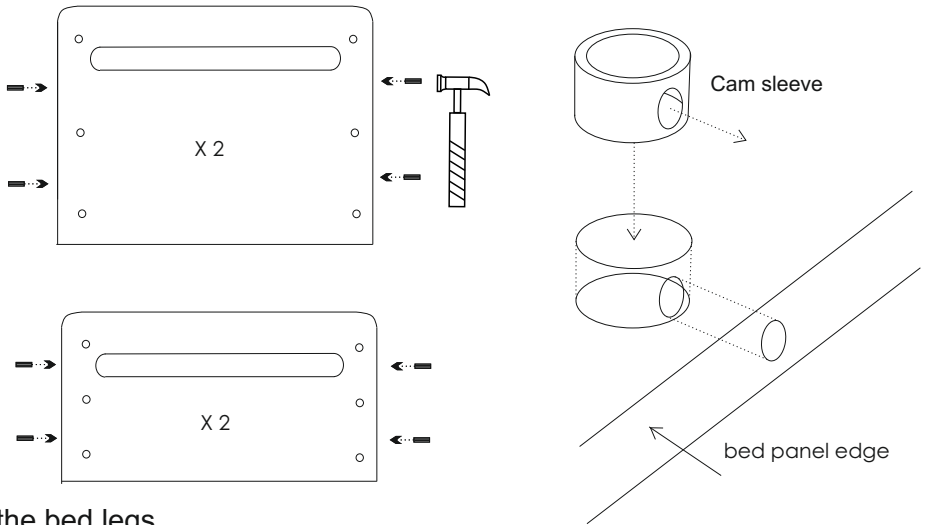

Fit the bed legs

You need: 24 x cam pins

Lay the bed legs out carefully pairing up the legs using the outer curve on the legs as a reference. Screw a cam pin into each of the metal inserts located in the leg slot. Note that the cam pins need to have the eyelet hole at 90 degrees to the long leg edge, see diagram (the pins do not need to be screwed down tight, the alignment is more important).

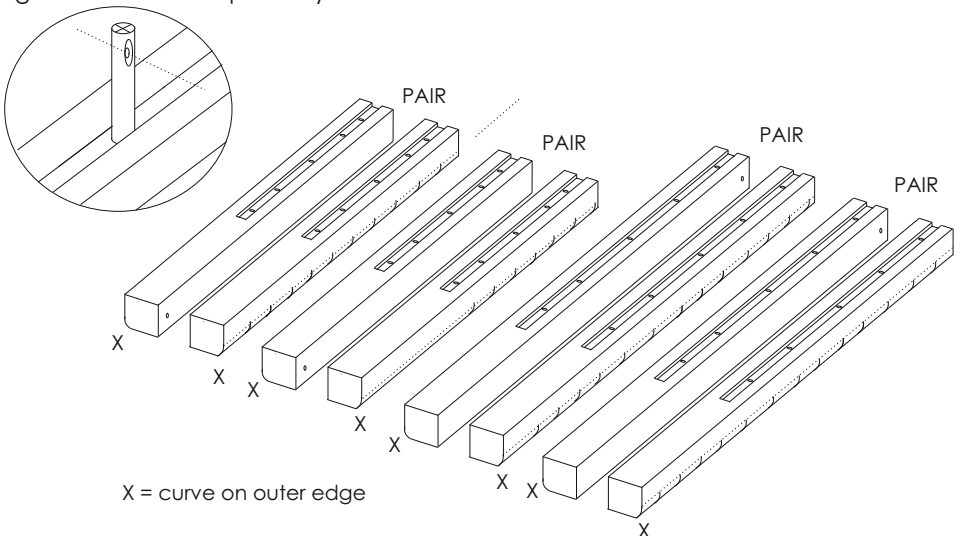

X = curve on outer edge

Making the large bed ends

12 cam grub screws

Align the large bed panel (panel with holes upwards) with a pair large bed legs observing the position of the bed legs outer edge curves. Push the parts together. Now insert the cam grub screws into the cam sleeves and tighten down once aligned. Repeat the process on the remaining large end. Note ; if the bushes do not tighten check cam pin hole is facing upwards, rotate cam pin on the leg if required.

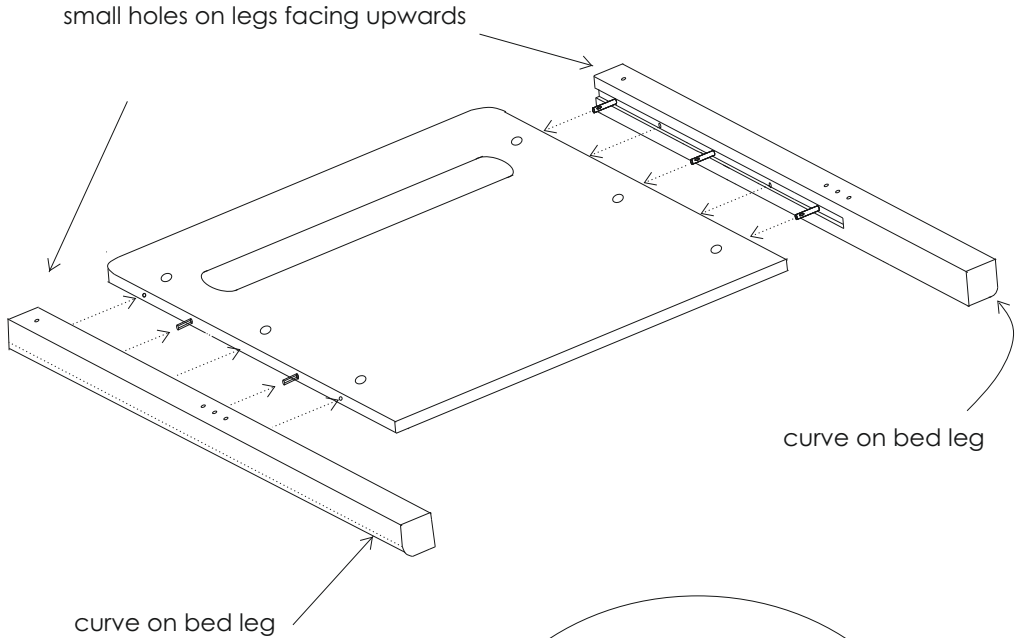

2 x large bed ends

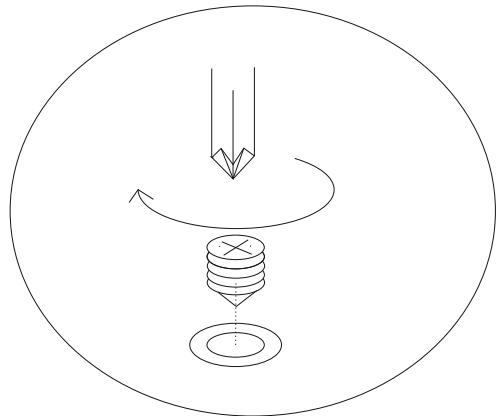

Making the small bed ends

12 cam grub screws

Align the large bed panel (panel with holes upwards) with a pair small bed legs observing the position of the bed legs edge curves. Push the parts together, inserting the cam grub screws into the cam sleeves and tighten down once aligned. Repeat the process on the remaining small end. Note ; if the bushes do not tighten check cam pin hole is facing upwards, rotate cam pin on the bed legs required.

small holes on bottom legs facing upwards

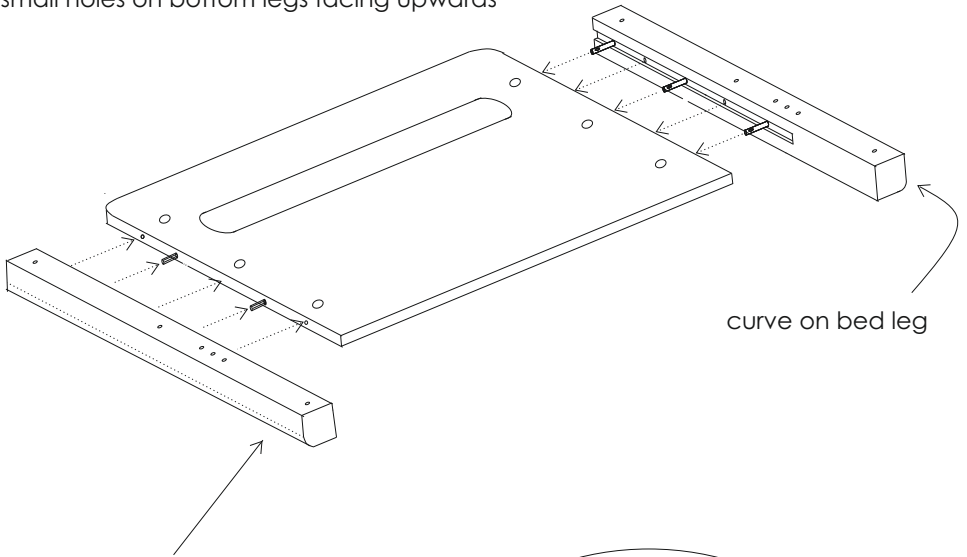

curve on bed leg

curve on bed leg

2 x small bed ends

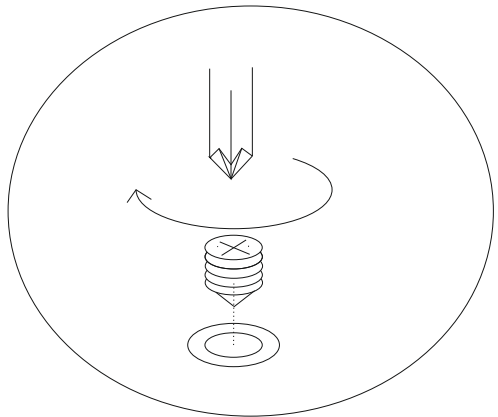

rotate Cam grub screw into the cam sleeve and tighten

Fitting the Rails

16 x small wooden dowels

Insert 2 wooden dowels into each end of each rail.

Gently tap dowels inwards until firmly in place.

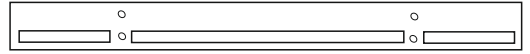
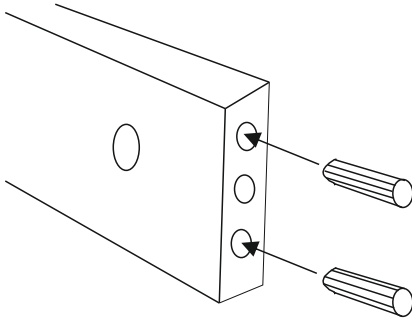
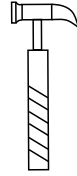

2 x Upper Rail

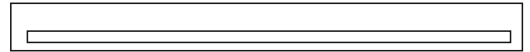

2 x Lower Rail

Making the large bed frame. 4 x long Bolts 9cm, 4 x Barrel nuts (two people)

Select both large bed frames and both lower bed rails (the lower bed rails have a inner rail which is full length). Align the lower mattress rails with the dowels locating into the two bed leg holes, inserting the 9cm bolt centrally from the outside of the bed frame, engaging the barrel nut fitted from the inside.

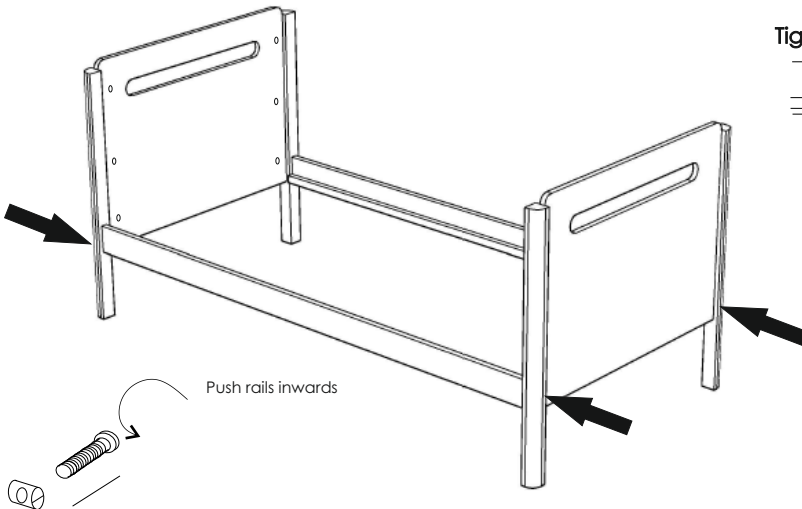
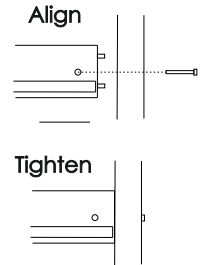

Making the small bed frame

4 x long Bolts 9cm, 4 x Barrel nuts (two people)

Select two small bed frames and two upper bed rails (the upper bed rails inner rail has two gaps). Align the lower mattress rails with the dowels locating into the two bed leg holes, inserting the 9cm bolt centrally from the outside of the bed frame, engaging the barrel nut fitted from the inside.

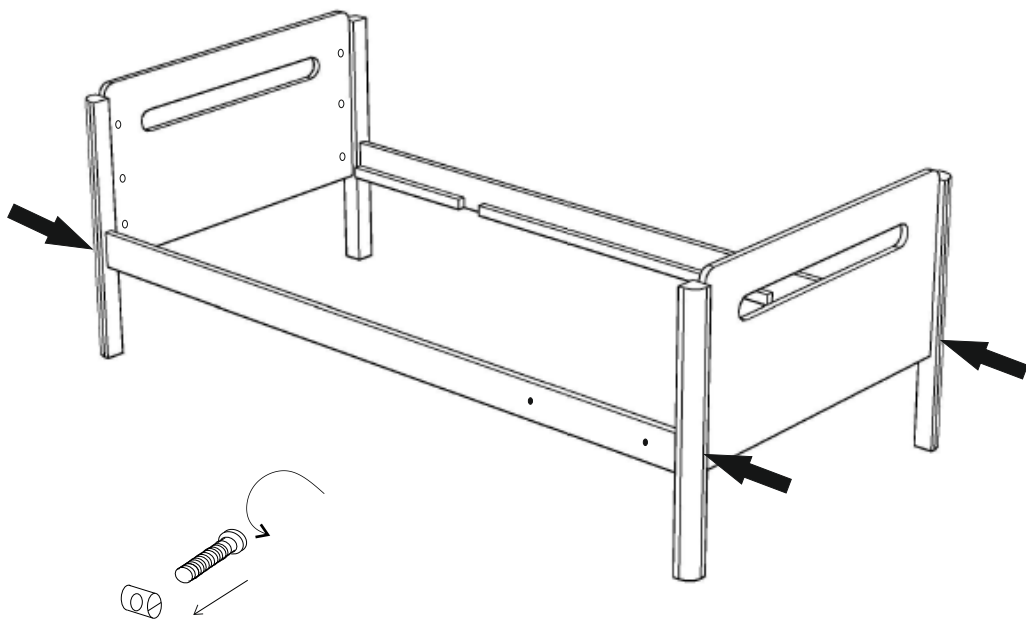
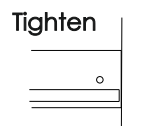
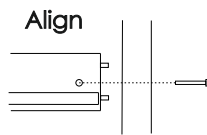

Orientating the bunk bed.

The small holes on the mattress rails are used to fix the ladder to the bed. You can have the ladder fitted on either the left or right side of the bunk bed. Simply rotate the bed frames, holes on the left for the LEFT-HAND entrance or holes on the right for the RIGHT-HAND entrance, see images below..

Both bed upper and lower bed frames need to be aligned the same way.

For the purposes of this instruction leaflet we will explain the assembly with the ladder on the RIGHT, for LEFT side fitting, simply mirror the actions explained and illustrated.

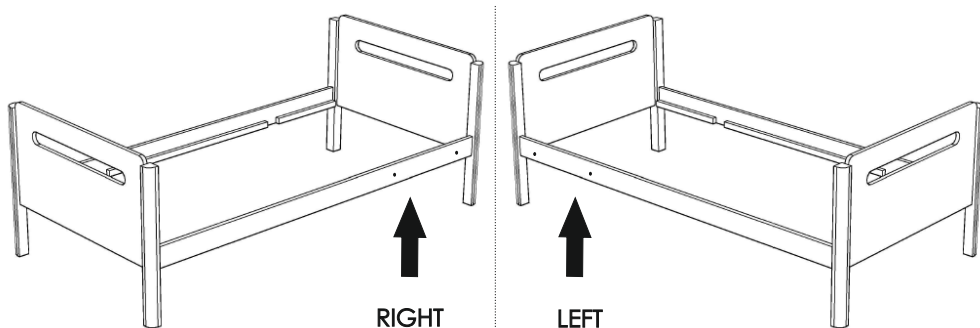

UPPER BED FRAME

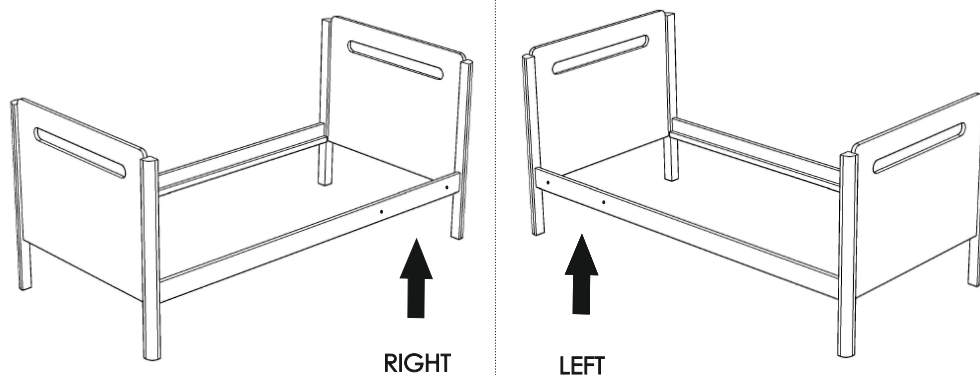

LOWER BED FRAME

Fixing the supports, upper bed frame. **IMPORTANT 3.5cm Bolts**

You need: 8 x short bolts 3.5cm and an allen key

Orientate the supports on to the inside of the mattress rails. Now connect each support to the bed using the bolts.



hand tight only

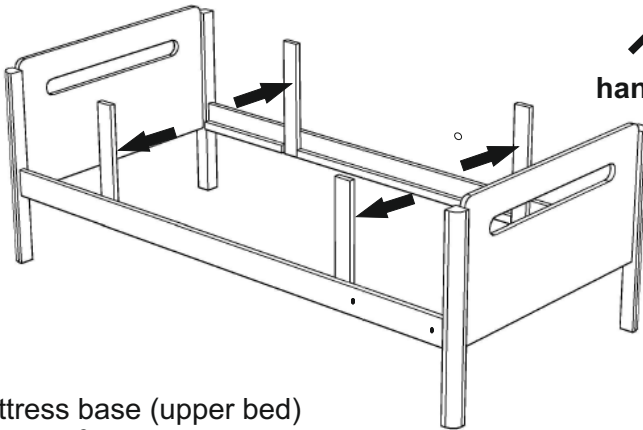

Fit the mattress base (upper bed)

34 x wood screws 3cm

Note: Please use TWO people to prevent scratching your bed.

Spread the mattress base out to full length on the floor, gently lift the bed base up & over the upper bed frame, lowering it down and around the internal vertical support rails. There should be four mattress laths at each end of the bed (between bed end and internal support rails).

Screw all the bed laths down EXCEPT the four bed laths positioned at the bed entrance. (we will return to these once the ladder is fitted)

Note: Please ensure that the bed lath fitted nearest to the bed end is positioned tight up to the bed end.

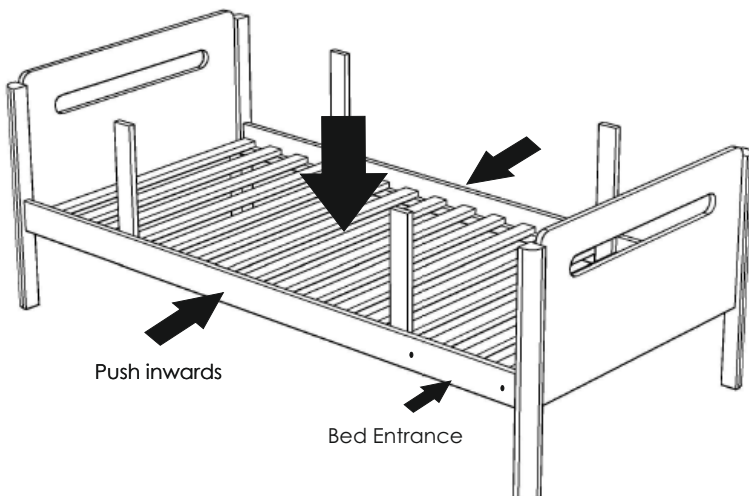

Some "light" inward pressure on the rails before screwing down the mattress base
This helps keep the bed parallel

Connecting the rear safety panel **IMPORTANT 3.5cm Bolts**

You need: 4 x short bolts 3.5cm, 4 x long bolts 9cm and 4 x barrel nuts

Please use two people to complete this assembly

Lift the rear safety panel into place, resting in up against the two support rails fitted in the previous steps. Now insert 4 long bolts into the panel end through the bed legs and connecting to 4 x barrel nuts. Do not fully tighten bolts at this stage. Insert the short bolts through each of the supports to attach the safety panel. Now go around and tighten all bolts.

note: You might need to loosen the rear mattress rail to allow the rear panel to slide into place.

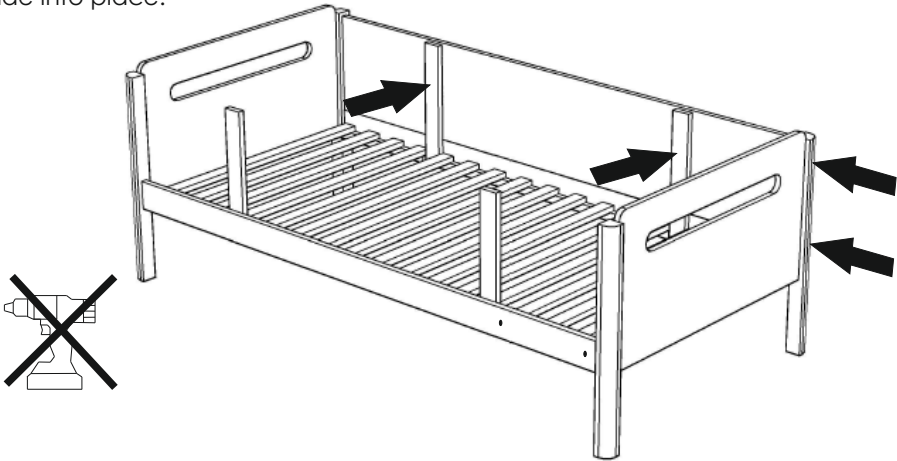

Fix the front safety panel **IMPORTANT 3.5cm Bolts**

4 x short bolts 3.5cm, 2 x long bolts 9cm and 2 x barrel nuts. (Ladder RIGHT)

Lift the front safety panel onto the bed with the barrel nut holes on the inside of bed, and up against the bed leg positioned opposite to the ladder entrance end.

Fit 2 x long bolts (9cm) through the bed leg and into the barrel nut inside facing holes. Insert the short bolts through each of the supports to attach the safety panel.

Now tighten all the fittings (front panel and rear panel) as this will strengthen up the bed frame

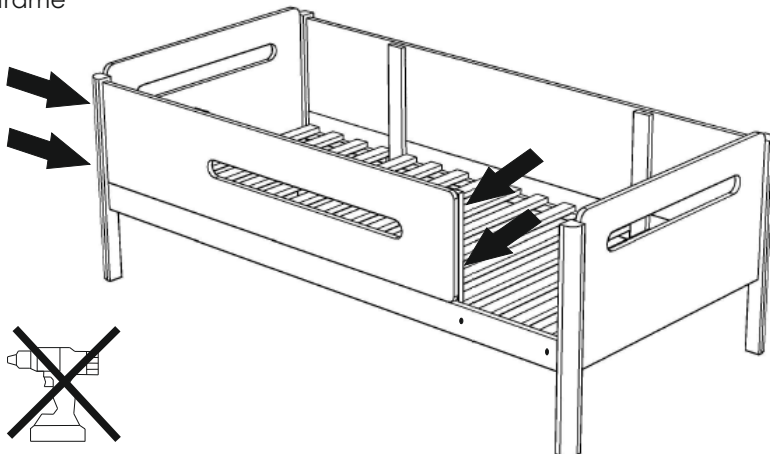

hand tight only

Fit the mattress base (Lower bed)

34 x wood screws (3cm)

Note: Please use TWO people to prevent scratching your bed.

Spread the mattress base out to full length on the mattress rails and screw every bed lath to the bed supports.

Note: Please ensure that the bed laths fitted nearest to the bed end are positioned tight up to the bed end.

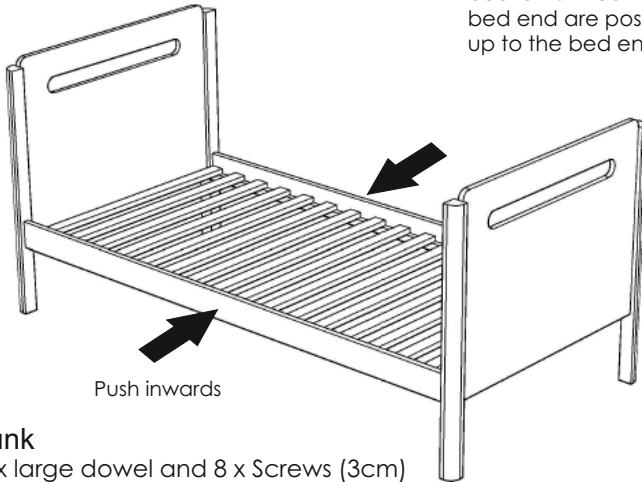

Make the bunk

You need: 4 x large dowel and 8 x Screws (3cm)

(TWO people to lift upper bed onto the lower bed).

Fit 4 x large wooden dowels into the top of the lower bed legs.

Lower the upper bed down onto the 4 wooden dowels projecting out of the lower bed legs.

Once both beds are firmly together insert screws into the 8 holes on either side of each join of the legs and tighten.

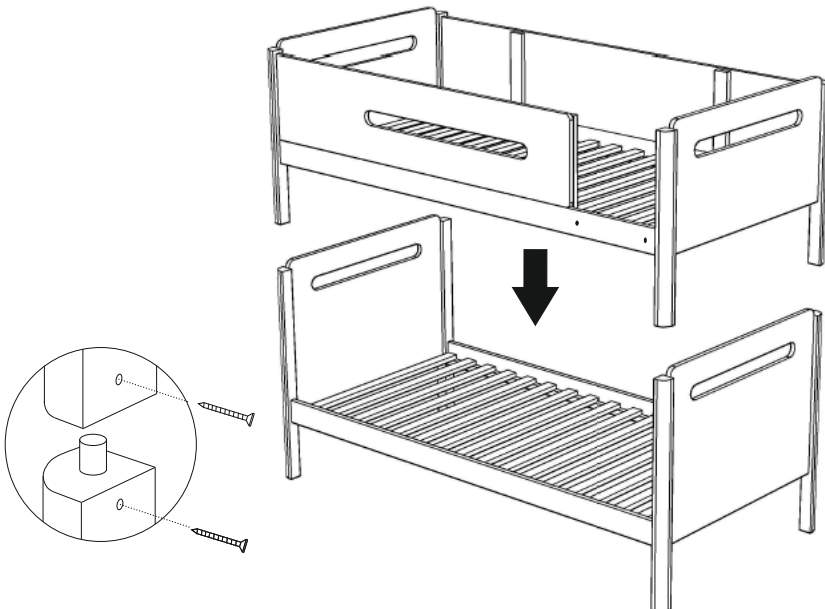

Fit the ladder. 6 x Bolts 4cm **IMPORTANT 4cm Bolts**

insert the three ladder treads into the ladder frame (plain side upwards) and connect each tread using 2 x 4cm bolt, tighten to complete.



hand tight only

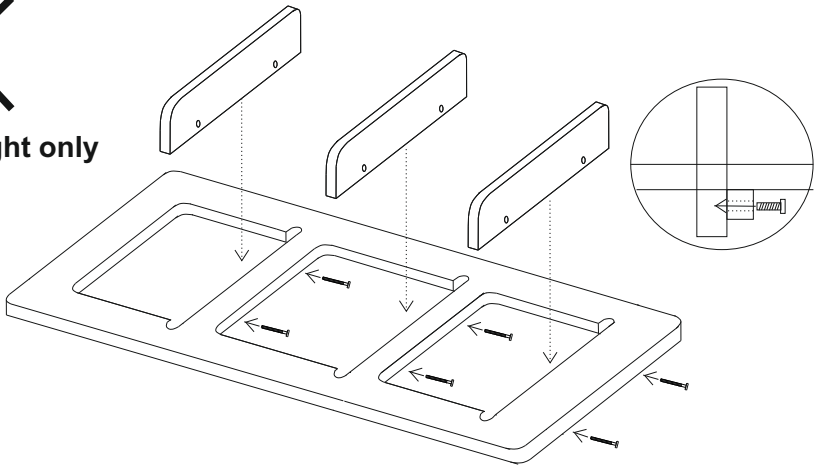

Fix the ladder to the bed **IMPORTANT 3.5cm Bolts**

You need: 4 x 3.5cm bolts

Place the ladder into the bed entrance (note that the upper bed laths are not fixed down)

Now connect the ladder through the two holes in the upper mattress rail and the two holes in the lower mattress rail using the four bolts. Tighten the bolts once all four bolts have been fitted.

Once the ladder is secure screw down the four remaining mattress laths on the upper bed, making sure that the last bed lath is tight to the bed end.

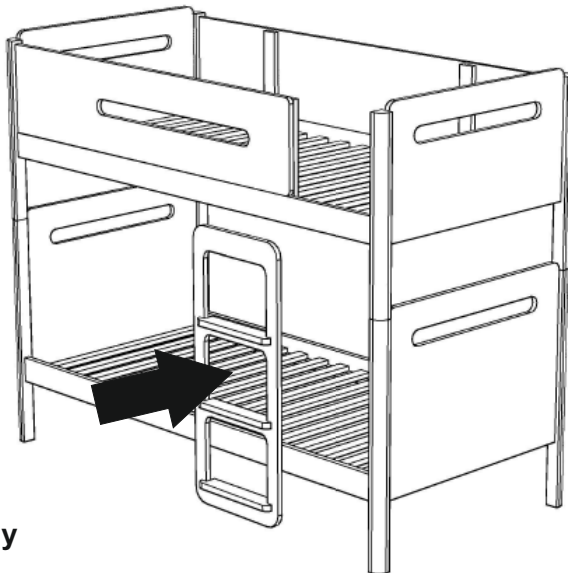

hand tight only

Check the bed

Now take a few minutes to look around the bed and tighten all the fittings as well as checking that the bed parts are firmly in place.

Your bed is now assembled.

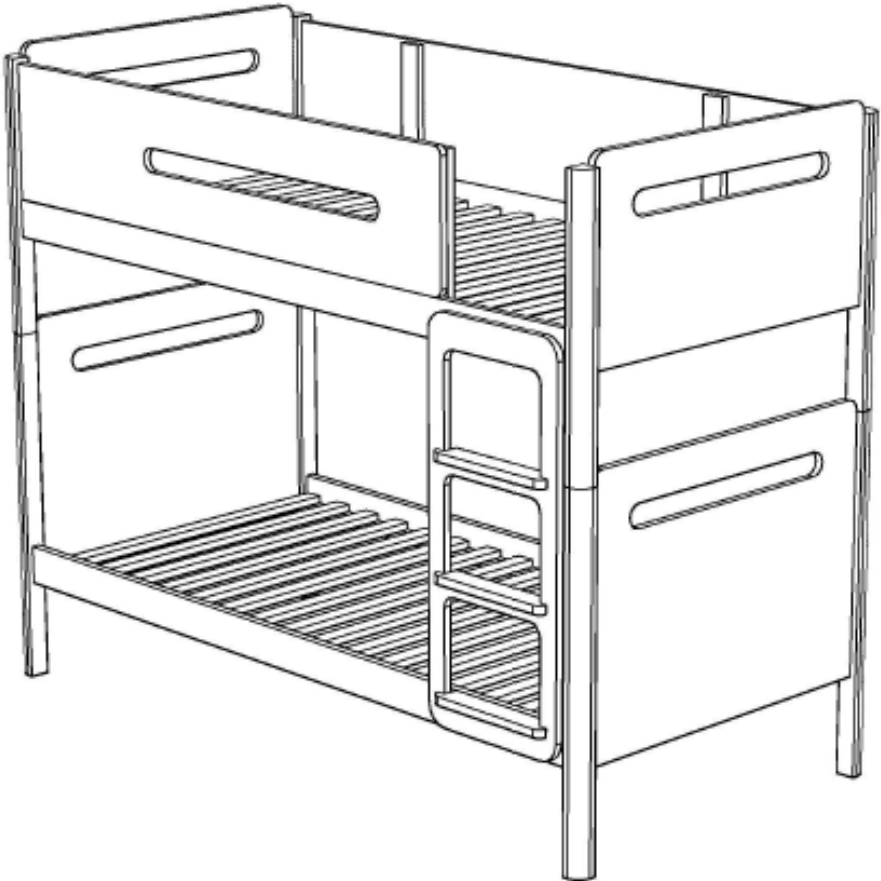

Fit the mattresses.(two people)

Carefully lift each mattress onto the sleeping surface.
Please use the correct sized mattresses for this product.

PRODUCT SAFETY

The MAXIMUM thickness of the UPPER BUNK mattress is 23cm.

The recommended size of the mattress is 190cm x 91 cm (6'3" x 3'0")

Periodically check that all assembly fixings are tightened properly, care should be taken to ensure that no fittings are loose.

Always follow the manufacture`s instructions.

WARNING "High beds and the upper bed of bunk beds are not suitable for children under six years due to the risk injury from falls".

WARNING "Bunk beds and high beds can present a serious risk of injury from strangulation if not used correctly. Never attach or hang items to any part of the bunk bed that are not designed to be used with the bed, for example, but not limited to ropes, strings, cords, hooks, belts and bags"

WARNING "Children can become trapped between the bed and the wall, a roof pitch, the ceiling, adjoining pieces of furniture (e.g. cupboards) and the like. To avoid risk of serious injury the distance between the top safety barrier and the adjoining structure shall not exceed 75mm or shall be more than 230mm.

Moving the bed

Do Not drag the bed.

Lift the bed into place by supporting both the end bed frames and mattress rails, keeping the bed assembly all together and in unison.

Splitting the bunk bed will reduce the weight of the product and help assist with repositioning the product.

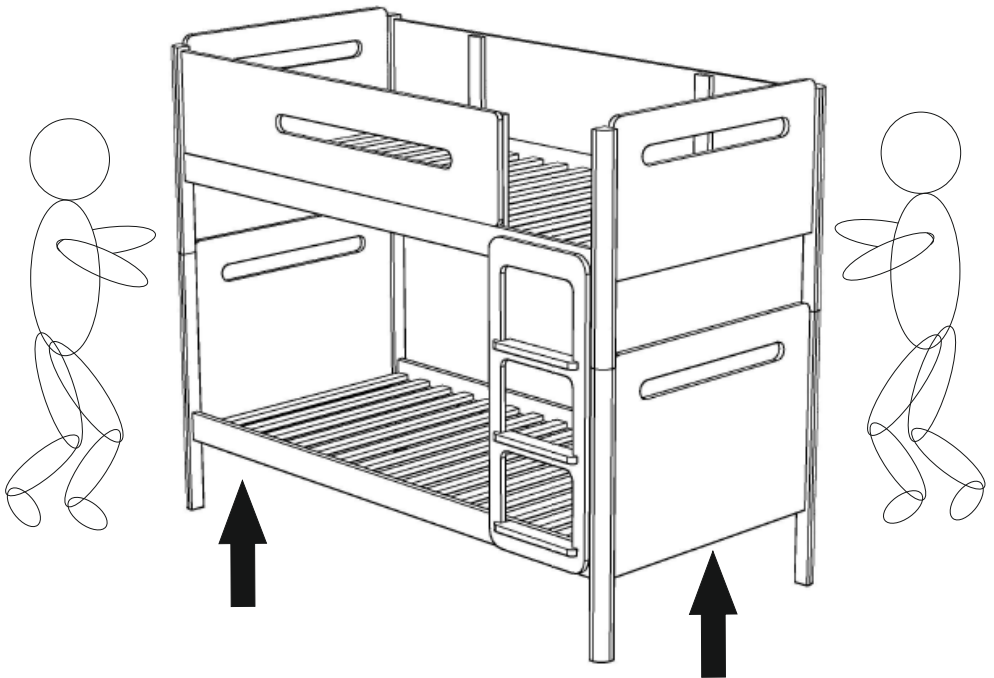

Make two single beds (option one)

Two people required.

Carefully remove the ladder, split the beds, remove the mattress bases and safety panels. Now switch one upper end with a lower end keeping the mattress rails fitted to one set of large ends, and tighten the bolts. Repeat the process on the other bed. Now fit the mattress bases to the beds.

The large panel bed ends can be rotated to hide the cam sleeve holes, this panel would then be facing outwards which is normally positioned against a property wall.

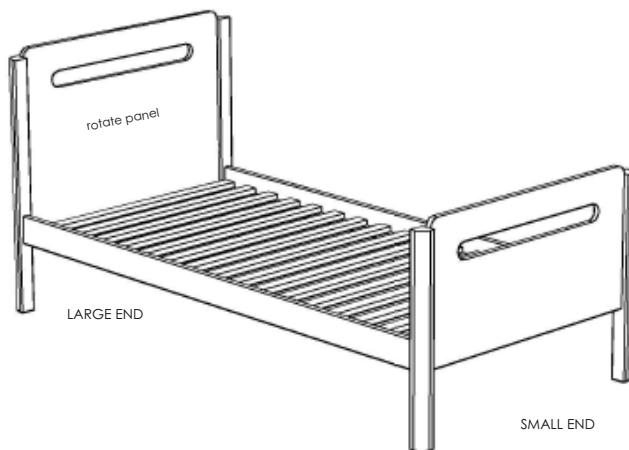

Make two single beds (option two)

Two people required.

Unscrew the screws fitted to the large connecting dowels, remove the ladder and lift the two beds apart.

The lower bed frame can be used as it stands, you can rotate the bed panel to hide the cam sleeve fittings should you wish to hide them, if positioned against a property wall.

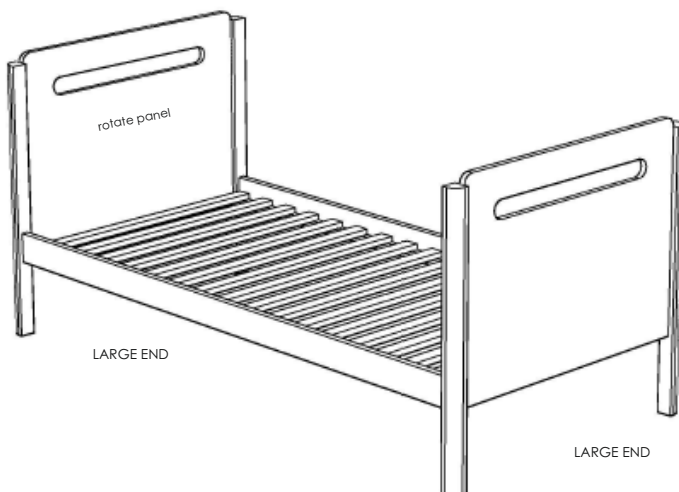

Make special bed (option one).

Two people required.

The upper bed frame can be used as it stands creating a toddler bed or first bed. Leaving the rear and front safety panel in position. By switching the panels you can change the bed entrance for the bed.

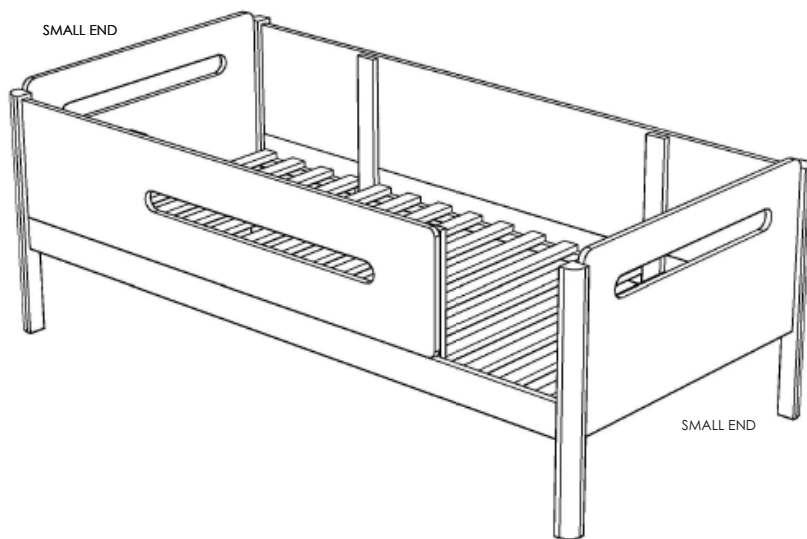

Make special bed (option two)

Two people required.

The upper bed frame can be used as a day bed, leaving the rear safety panel in place.

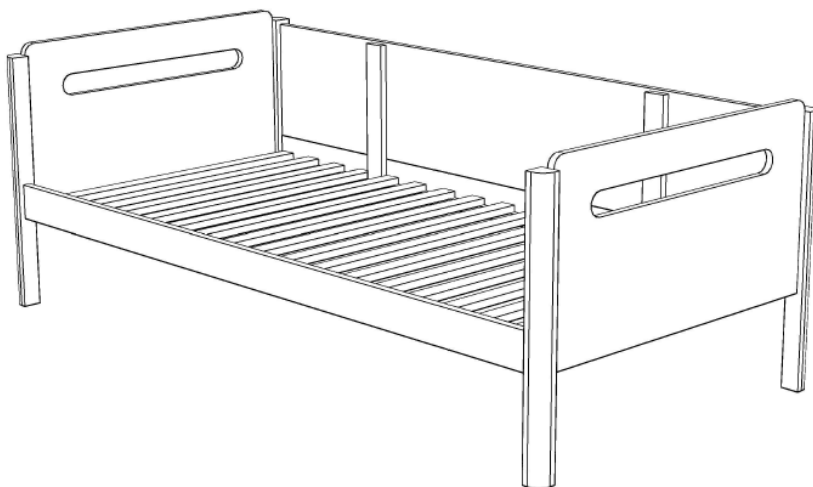

PRODUCT SAFETY

Single bed / Special bed

Additional information

The recommended size of the mattress is 190cm x 91cm (6'3" x 3'0")

Periodically check that all assembly fixings are tightened properly, care should be taken to ensure that no fittings are loose.

Always follow the manufacture's instructions.

Please ensure that good ventilation is maintained within the room in order to keep humidity low and to prevent mould in and around the bed;

WARNING Do not place this child's bed near heat sources, windows and other furniture.

WARNING Do not use this child's bed if any part is broken, torn or missing.

WARNING Hole covers Not suitable for children under 36 months due to choking hazard.

The bed can be dismantled for storage or transportation.

Children are likely to play, bounce, jump and climb on beds, therefore the child's bed should not be placed too close to other furniture or windows, blind cords, curtain pulls or other strings or cords and should be placed either tight to any wall or have a gap of 300mm between the wall and the side of the bed.

Additional or replacement parts should be obtained from Little Folks Furniture.

Moving the bed

Do Not drag or twist the bed.

Lift the bed into place by supporting both the end bed frames and mattress rails, keeping the bed assembly all together and in unison. Removing the mattress will help reduce the overall weight of the bed.

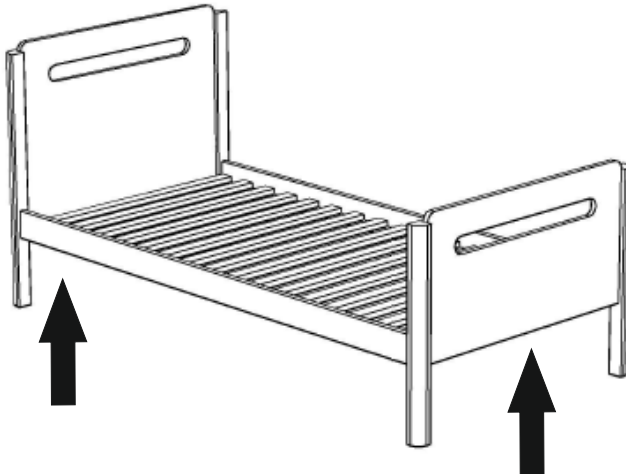

Notes;